

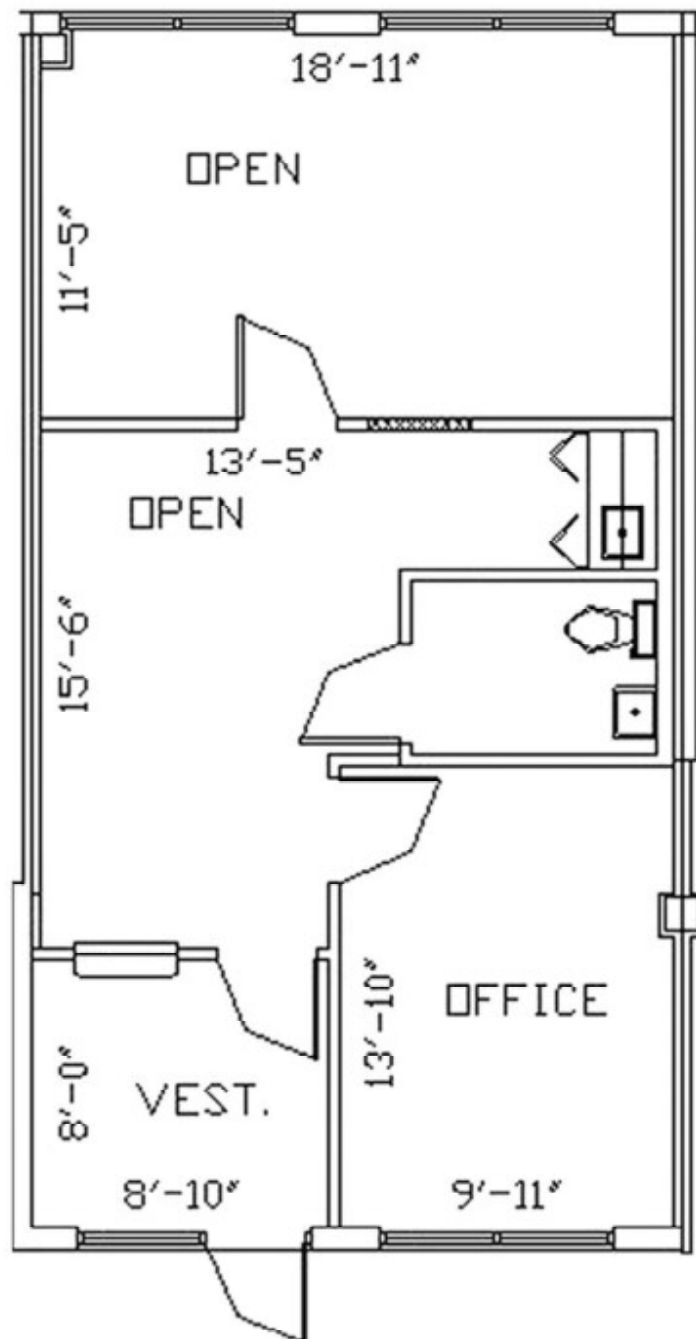

The Preserve at 7700 Congress
7700 Congress Avenue
Boca Raton, FL 33487

- Campus- Style Environment
- Seconds From I-95
- Efficient 600 and 1,000 sf Layouts
- Roving Security, Impact Glass



Suite 2102 - 796 SF



One Boca Commerce Center
551 NW 77th Street
Boca Raton, FL 33487

- 2- Story Lakefront Office
- Seconds to I-95 via Congress Interchange
- Newly Renovated
- Security Patrol After Hours/Weekends

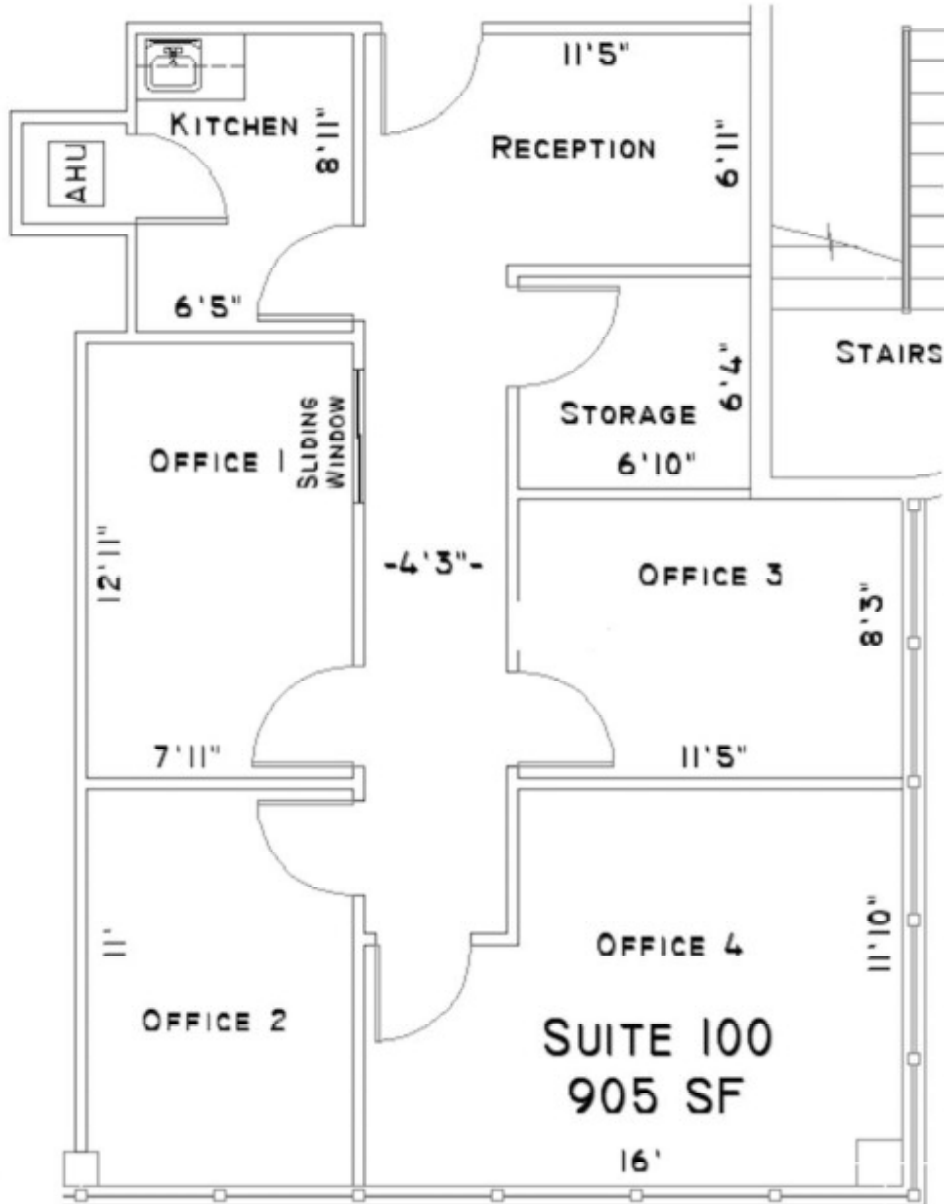



One Boca Commerce Center
551 NW 77th Street
Boca Raton, FL 33487

- 2-story office building
- Seconds to I-95
- Lake Views
- Major Renovation for 2009

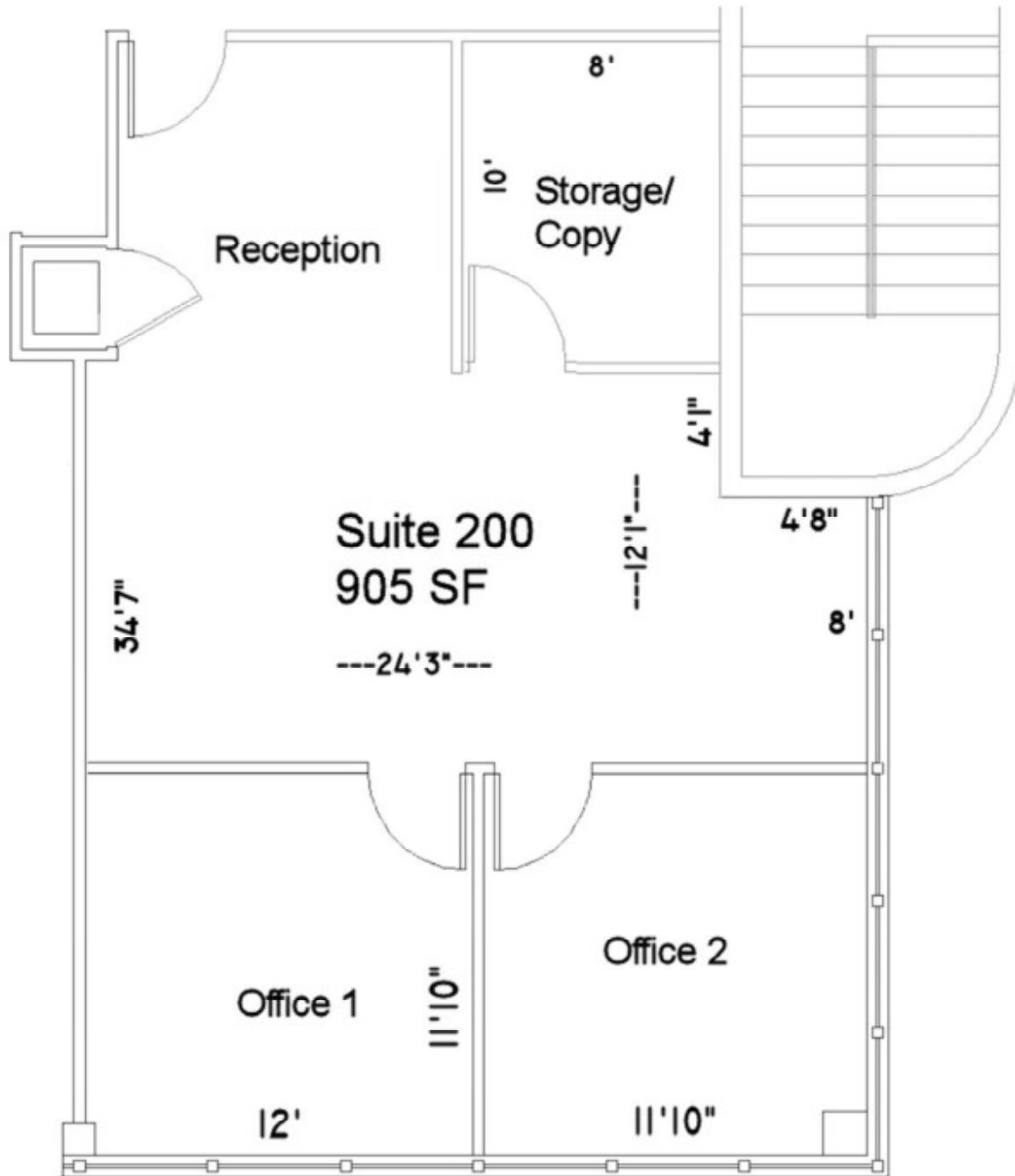



The Preserve at 7700 Congress
7700 Congress Avenue
Boca Raton, FL 33487

- Campus-Style Environment
- Standrd Sizes 600 and 1,000 sf
- Impact Glass
- Roving Security

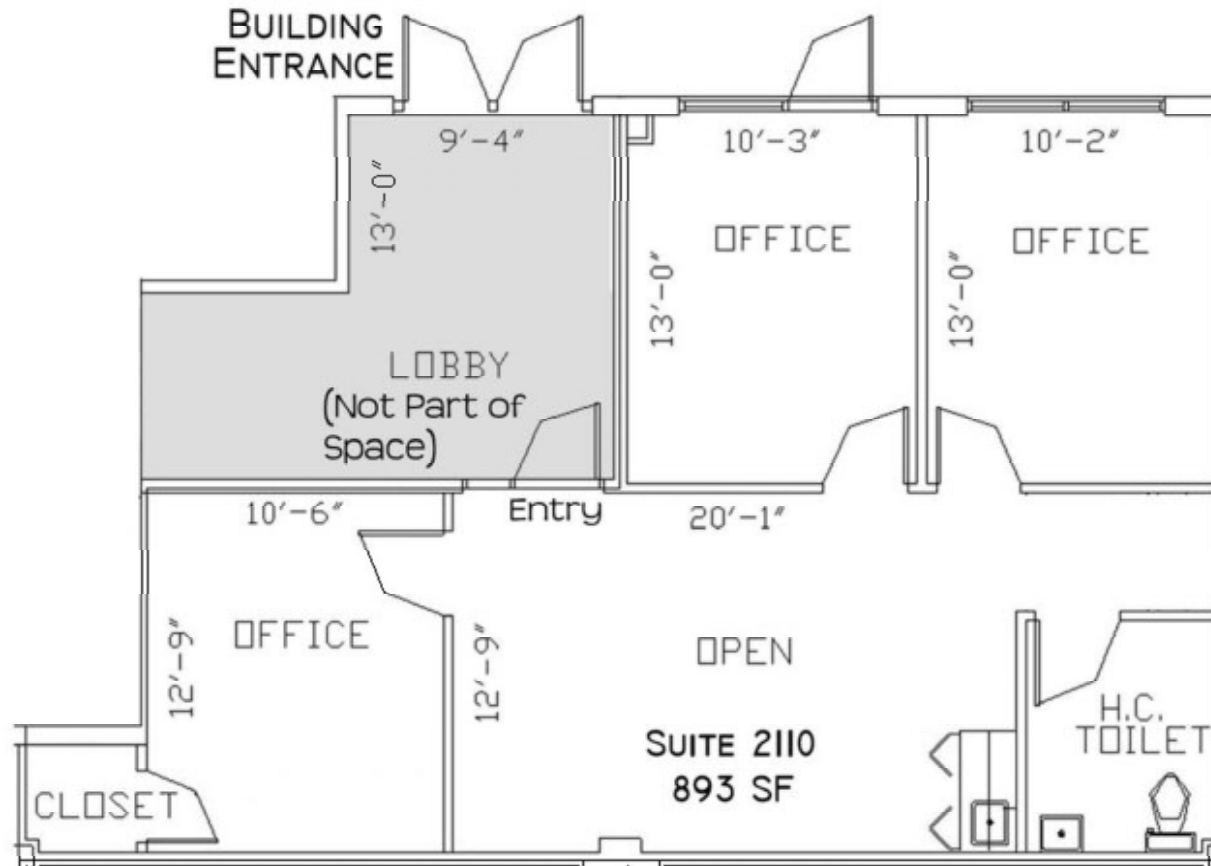

Danburg Management Corporation
7700 Congress Avenue, Suite 3100
Boca Raton, FL 33487
561.997.5777 - www.danburg.com



- Peninsula Corporate Center
- Full Generator Backup
 - Spectacular Fountain Courtyard
 - Seconds to I-95
 - Security Cameras, Electronic Access
 - Roving Guard Patrol

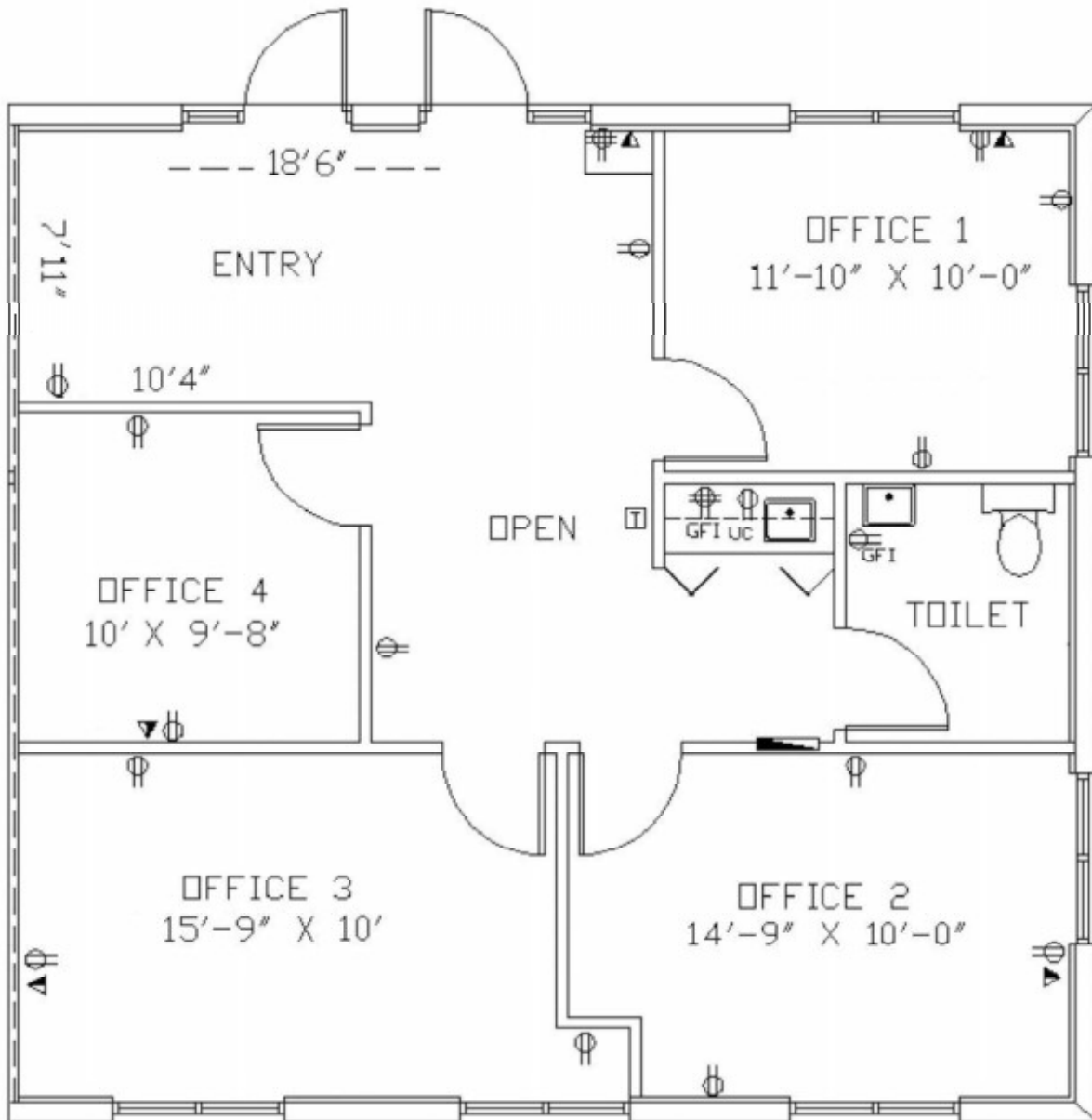

Suite 3014

951 sf



The Preserve at 7700 Congress
7700 Congress Avenue
Boca Raton, FL 33487

- Campus-Style Environment
- Standrd Sizes 600 and 1,000 sf
- Impact Glass
- Roving Security

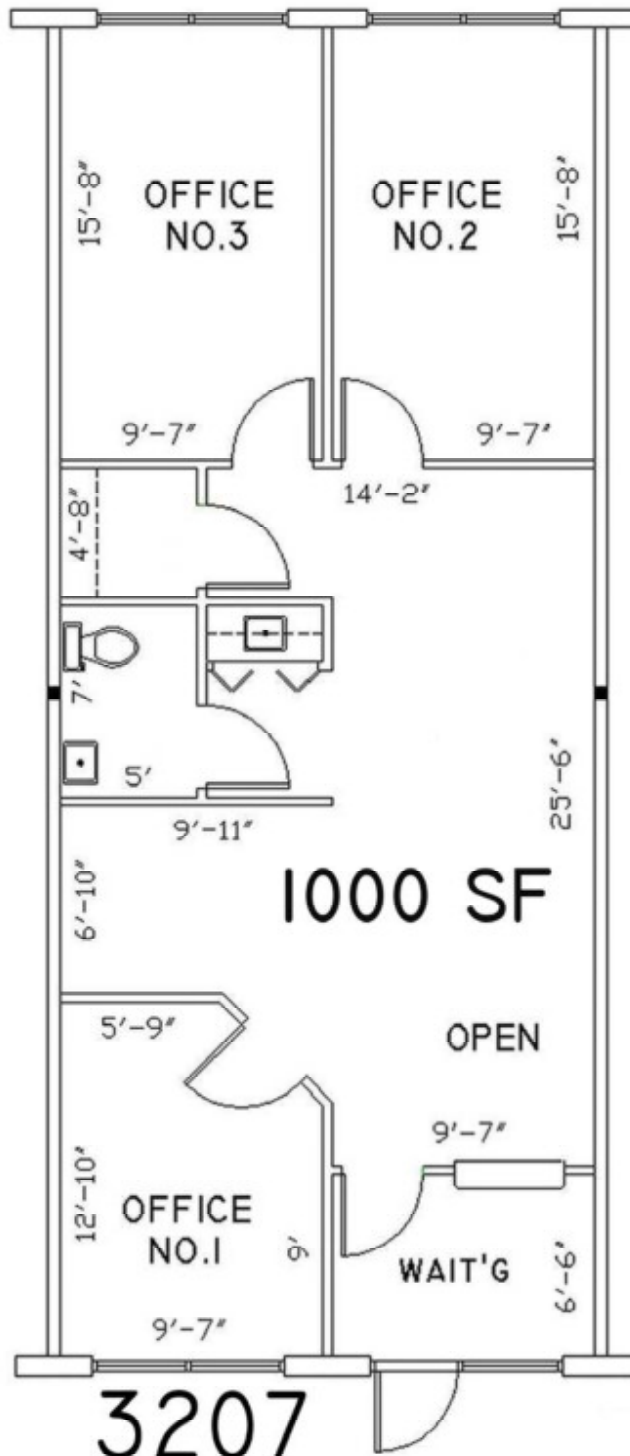



The Preserve at 7700 Congress
7700 Congress Avenue
Boca Raton, FL 33487

- Campus-Style Environment
- Standrd Sizes 600 and 1,000 sf
- Impact Glass
- Roving Security

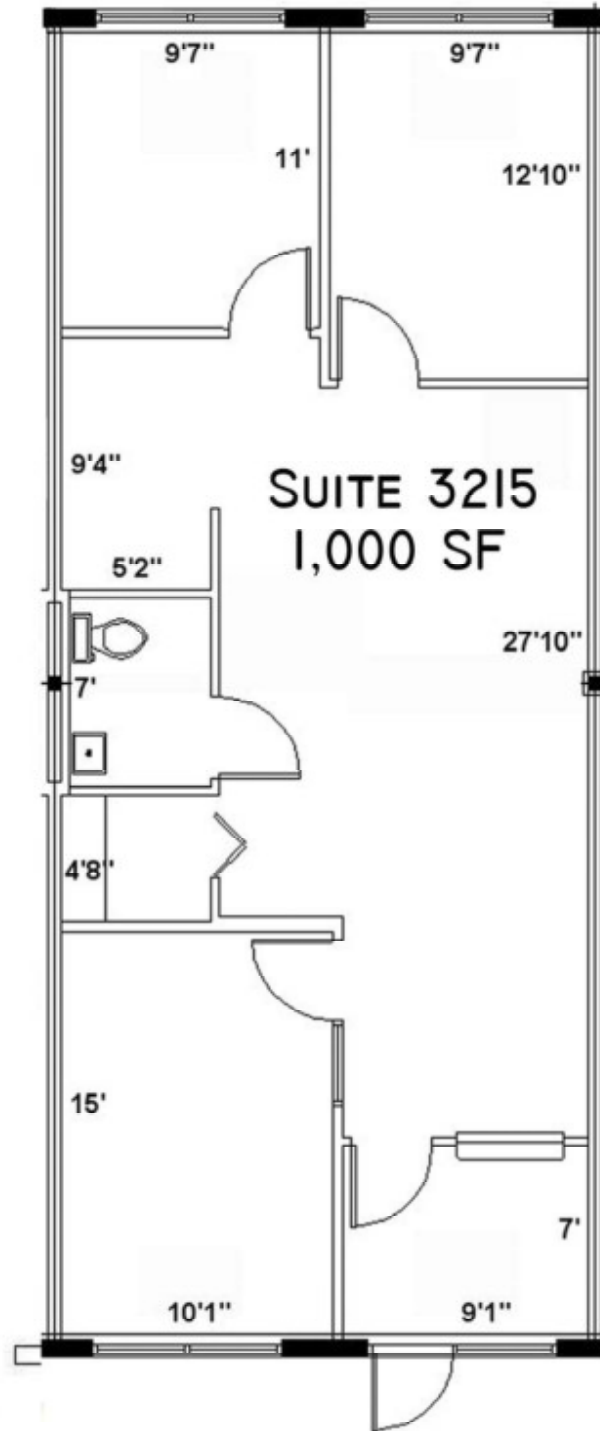



- Peninsula Corporate Center**
- Full Generator Backup
 - Spectacular Fountain Courtyard
 - Seconds to I-95
 - Security Cameras, Electronic Access
 - Roving Guard Patrol

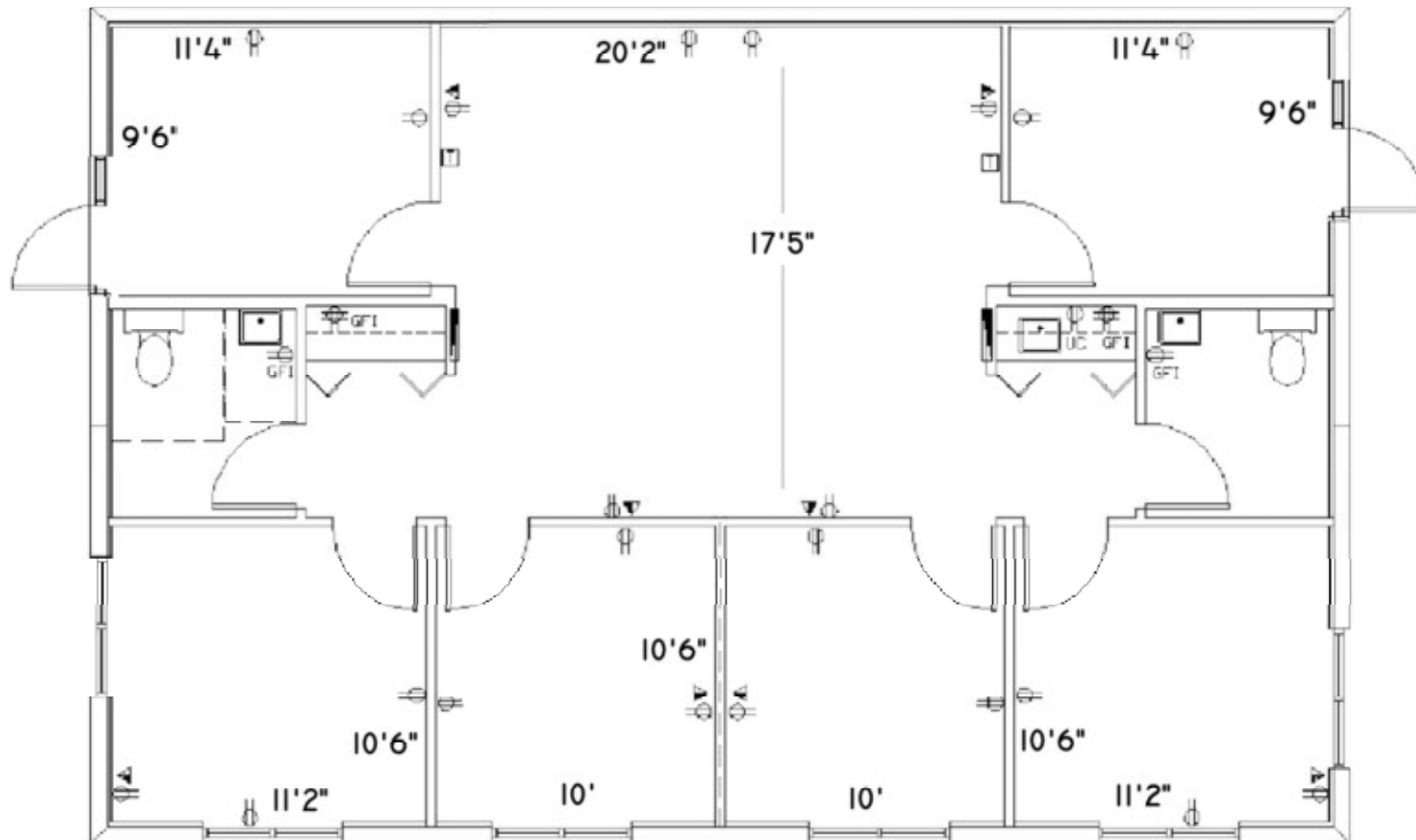

Suite 1008-9 1,347 SF



The Preserve at 7700 Congress
7700 Congress Avenue
Boca Raton, FL 33487

- Campus-Style Environment
- Standrd Sizes 600 and 1,000 sf
- Impact Glass
- Roving Security

